



Super Tortilla Machines



T5000

Dimensions	
Length	66 in (168 cm)
Wide	28 in (71 cm)
Height	51 in (130 cm)
Weight	1200 lbs (545 kg)
Build Materials	- Aluminum head (stainless steel upon request) - Stainless steel covers - Heavy duty bearings - Iron body - Heavy duty gear box - High efficiency burners - Zytel 42 FG (Food Grade) or Similar Material with Same Mechanical and Food Grade Characteristics Rollers

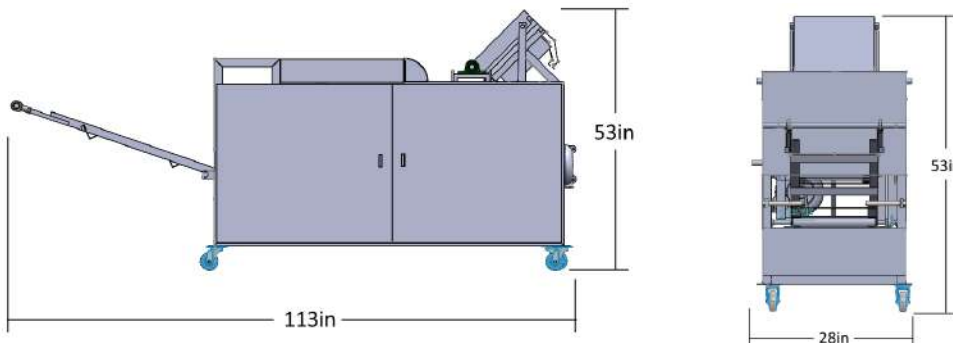

Electrical Consumption	1.2 KWH
Hertz	60Hz / 50Hz (50 upon request)
Volts	110V, 220-240V AC
Motor Size	1.5 HP
Production	
Pieces per hour	1000 pz to 1500 pz / hr
Max Tortilla Size	8 in (20 cm)
Min Tortilla Size	4 in (10 cm) or smaller
Adjustable Size	Yes
Flour/Dough Type	Corn
Customization	This machine can be customized. Can be made for bigger tortillas and for different electrical systems. Can also use different shape cutters.
Energy Consumption	
BTU	150,000 BTU
Gas Consumption	3.5 lt/hour
Gas Type	Natural / Propane

TS Products and Services C. 543 Americas Ave., Suite B-6, El Paso TX 79907, USA Tel +1-915-400-5845
sales@supertortillamachines.com