



# Super Tortilla Machines



## C2000 ALL ELECTRIC

Dimensions	
Length	71 in (180 cm)
Wide	35 in (89 cm)
Height	60 in (152 cm)
Weight	1200 lbs (800 kg)
Build Materials	- Aluminum head (stainless steel upon request) - Roller - Zytel 42 FG (Food Grade) or Similar Material with Same Mechanical and Food Grade Characteristics - Stainless steel covers - Heavy duty bearings - Iron body - Heavy duty gear box - High efficiency electrical resistances.

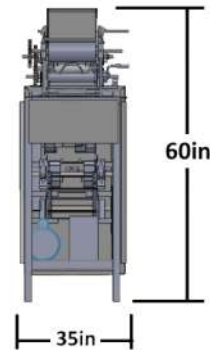
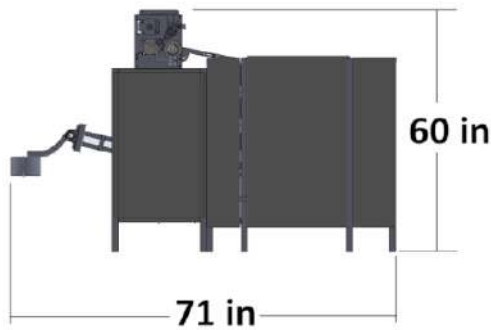

Electrical Consumption	35 KWH
Hertz	60Hz / 50Hz (50 upon request)
Volts	220-240V AC - 3ph
Motor Size	1HP
Production	
Pieces per hour	800-1200 tortillas
Max Tortilla Size	8 in (20 cm)
Min Tortilla Size	4 in (10 cm) or smaller
Adjustable Size	Yes (with cutters)
Flour/Dough Type	Corn
Customization	This machine can be customized. Can be made for bigger tortillas and for different electrical systems. Can also use different shape cutters.

**TS Products and Services C. 543 Americas Ave., Suite B-6, El Paso TX 79907, USA Tel +1-915-400-5845**

**sales@supertortillamachines.com**